

# HEDCON<sup>®</sup> Worm Gear Reducer

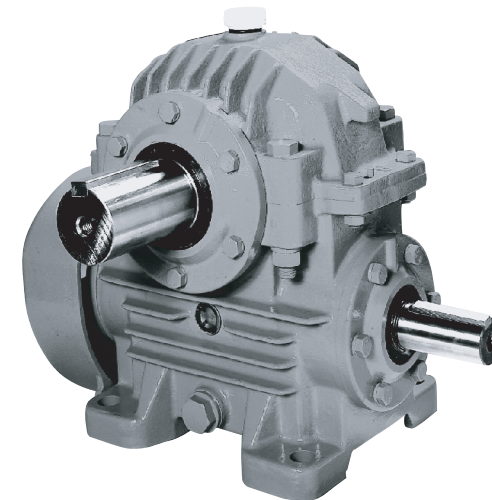

- The gear motor and reducer should be handled, installed and maintained by trained technicians. Carefully read the maintenance manual before use.
- A copy of this maintenance manual should be sent to the actual user .
- This maintenance manual should be maintained by the user.

 **Sumitomo Heavy Industries, Ltd.**

POWER TRANSMISSION & CONTROLS GROUP

5-9-11, KITA-SHINAGAWA SHINAGAWA-KU, TOKYO 141-8686, JAPAN  
PHONE: (03)5488-8363 FAX: (03)5488-8365  
TELEX: J24580 SUMIJUKA

## [Safety and other precautions]

- Carefully read this maintenance manual and all accompanying documents before use (installation, operation, maintenance, inspection, etc.). Thoroughly understand the machine, information about safety, and all precautions for correct operation. Maintain this manual for future reference.
- Pay particular attention to the "DANGER" and "CAUTION" warnings regarding safety and proper use.



: Improper handling may result in physical damage, serious personal injury and/or death.



: Improper handling may result in physical damage and/or personal injury.

Matters described in  CAUTION may lead to serious danger depending on the situation. Be sure to observe important matters described herein.

### DANGER

- Transport, installation, plumbing, wiring, operation, maintenance, and inspections should be handled by properly trained technicians; otherwise, electric shock, injury, fire, or damage to the equipment may result.
- When the unit is to be used in a system for transport of human beings, a secondary safety device should be installed to minimize chances of accidents resulting in injury, death, or damage to the equipment.
- When the unit is to be used for an elevator, install a safety device on the elevator side to prevent it from falling; otherwise, personal injury, death, or damage to the equipment may result.

- Refer to the Cyclo maintenance manual (Cat. No. CM0101E) for the handling of Cyclo portion of gearmotors and reducers with Cyclo .
- Refer to the three – phase squirrel – cage induction motor manual (Cat. No. MM0401) for the handling of gearmotors with a three – phase motor .
- Refer to the brake maintenance manual (Cat. No.MM0202E) for the handling of gearmotors with a brake .

## ———— CONTENTS ————

1.	Inspection upon delivery .....	3
2.	Storage .....	6
3.	Transport .....	7
4.	Installation .....	8
5.	Coupling with other machines .....	9
6.	Operation .....	11
7.	Daily inspection and maintenance .....	13
8.	Disassembly and assembly .....	16
9.	Troubleshooting .....	17
10.	Construction drawing .....	18
11.	Bearing list .....	19
12.	Oil seals list .....	19
13.	Warranty .....	20

## 1. Inspection upon delivery

### ! CAUTION

- Unpack the unit after verifying that it is positioned right side up; otherwise, injury may result.
- Verify that the unit received is in fact the one you ordered. When a different unit is installed, injury or damage to the equipment may result.
- Do not remove the rating plate.

Upon delivery and receipt of the reducer check the following. If a nonconformity or problem is found, contact our nearest agent, distributor, or sales office.

- (1) Do the items on the rating plate conform to what you ordered?
- (2) Was there any part broken during transport?
- (3) Are all bolts and nuts tightened firmly?

### 1 – 1) How to refer to the rating plate

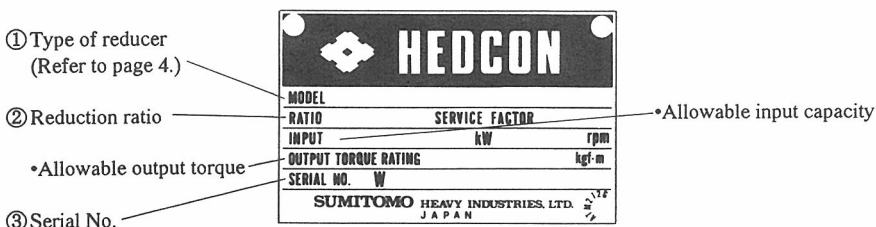

Fig.1 Rating plates

- When making an inquiry, advise us of ① The type of reducer ② Reduction ratio ③ Serial No.

### 1 – 2) Lubrication method

Lubrication method for gear portion of standard model is oil bath. Lubrication methods for bearings of standard model are oil bath and splash oil.

- The units are shipped without any oil. Proper amount of oil (Refer to page 14 Table5) should be supplied before start – up.



### 1 – 3) Type of reducer

Respective codes and Hedcon nomenclature is shown below. Please check to see if the type of gearmotor or reducer you have conforms to what you ordered.

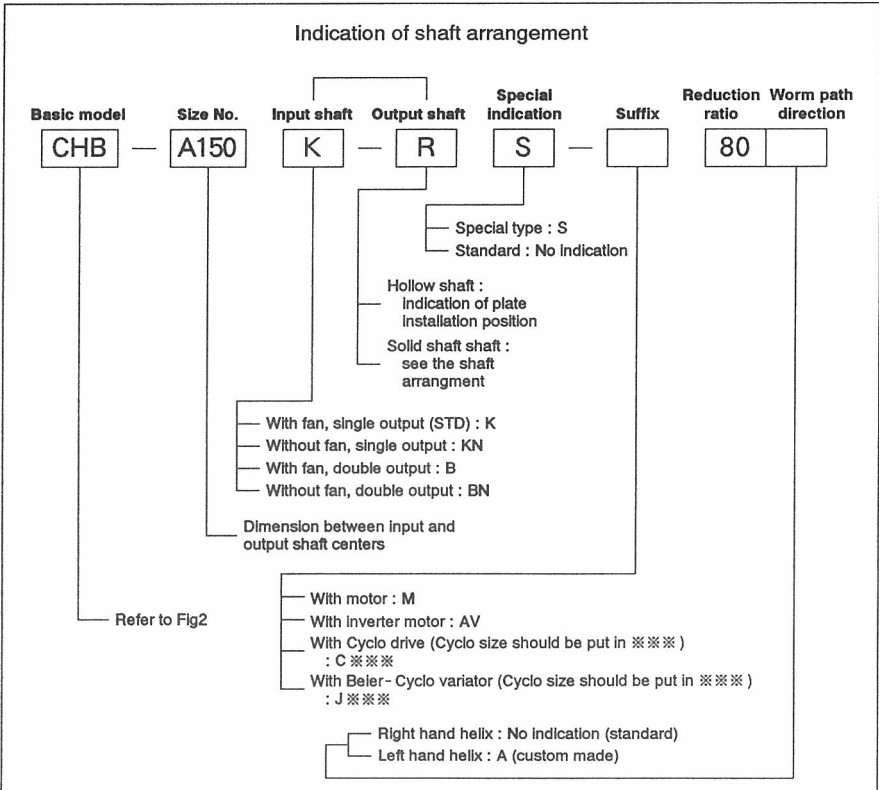
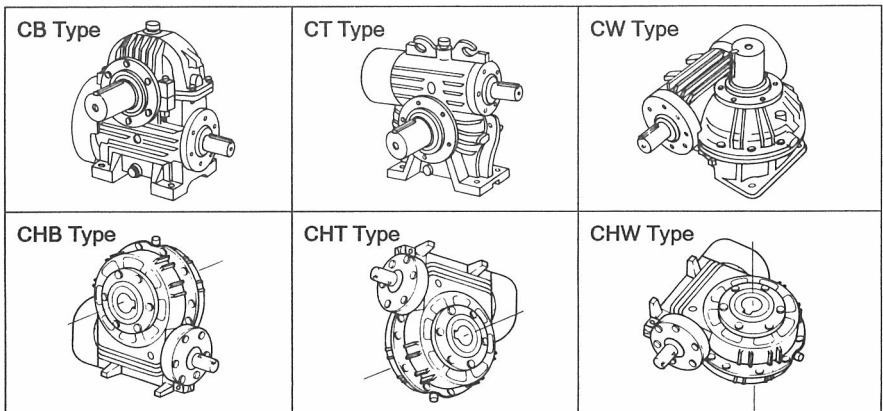
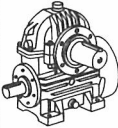
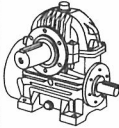
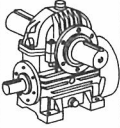

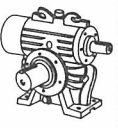
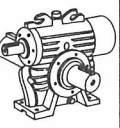

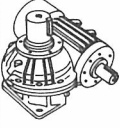

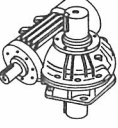



Fig.2 Basic models



**Fig.3 Indication of shaft arrangement (Example of CB, CT, CW Type)**

CB Type						
CT Type						
Single input shaft	K(KN) - R	K(KN) - L	K(KN) - B	K(KN) - R	K(KN) - L	K(KN) - B
Double input shaft	B(BN) - R	B(BN) - L	B(BN) - B	B(BN) - R	B(BN) - L	B(BN) - B
CW Type						
Single input shaft	K(KN) - RU	K(KN) - RD	K(KN) - LU	K(KN) - LD	K(KN) - RB	K(KN) - LB
Double input shaft	B(BN) - RU	B(BN) - RD	B(BN) - LU	B(BN) - LD	B(BN) - RB	B(BN) - LB

Shaft arrangement indication R refers to an arrangement where the low speed shaft is positioned on the right – hand side, as viewed from the high speed shaft (worm shaft) side, with the legs on the horizontal plane. Similarly, letters L, U, D and B indicate the low speed shaft on the left – hand side, upwards, downwards, and on both side, respectively.

**Fig.4 Indication of plate installation position (Example of CHB, CHT, CHW Type)**





CHB Type						
CHT Type						
Single input shaft	K(KN) - R	K(KN) - L	K(KN) - B	K(KN) - R	K(KN) - L	K(KN) - B
Double input shaft	B(BN) - R	B(BN) - L	B(BN) - B	B(BN) - R	B(BN) - L	B(BN) - B
CHW Type						
Single input shaft	K(KN) - RU	K(KN) - RD	K(KN) - RB	K(KN) - LU	K(KN) - LD	K(KN) - LB
Double input shaft	B(BN) - RU	B(BN) - RD	B(BN) - RB	B(BN) - LU	B(BN) - LD	B(BN) - LB

Plate installation position code R indicates that the plate installed on either CHB, T or W type is positioned on the right – hand side, as viewed from the high speed shaft (worm shaft) side. Likewise, code letters L, U, D and B indicate that the plate is positioned on the left – hand side, upwards, downwards, and on both sides, respectively.

● Indication examples

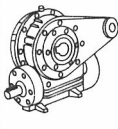
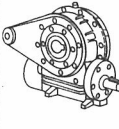
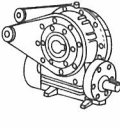
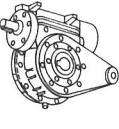
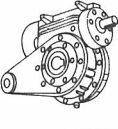
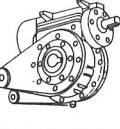
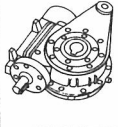
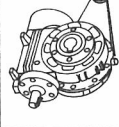
- CB- A100 K- R 50
- CW- A100 KN- RU- S 20
- CHT- A250 KN- R 10A

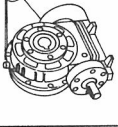
## 2. Storage

When storing reducers for any extended period of time, consider the following important points.

### 2 – 1) Storage location

Store the unit in a clean, dry place indoors.

- Avoid storage outdoors or in places with humidity, dust, sudden temperature change, or corrosive gas.

### 2 – 2) Storage period

- (1) Storage period should be less than 6 months.
- (2) When the storage period exceeds 6 months, special rust prevention is necessary.  
Contact us for details.
- (3) Export models need export rust prevention. Contact us for details.

### 2 – 3) Use after storage

- (1) Oil seals, oil gauge, oiling plug etc. will deteriorate when exposed to high temperatures and UV rays. Inspect the oil seals before operation.  
Replace the oil seals with new ones after long – term storage if there is any sign of deterioration.
- (2) After starting Hedcon, check that there is no abnormal sound, vibration, or heat built – up. If supplied as a broke motor check that the broke operates properly.  
If any anomaly is observed, contact our nearest agent, distributor, or sales office.

### 3. Transport

#### DANGER

- Do not stand directly under a unit suspended by a crane or other lifting mechanism; otherwise, injury or death may result.

#### CAUTION

- Exercise ample care so as not to drop the reducer. When a hanging bolt or hole is provided, be sure to use it. After mounting a unit on the equipment, do not hoist the entire equipment using the hanging bolt or hole; otherwise, injury or damage to the equipment and/or lifting device may result.
- Before hoisting, check the weight of the reducer by referring to the rating plate, crate, outline drawing, catalog, etc. Never hoist a unit that exceeds the rating of the crane or other mechanisms being used to lift it; otherwise, injury or damage to the equipment and/or lifting device may result.

## 4. Installation

### CAUTION

- Do not use the reducer for purposes other than those shown on the rating plate or in the manufacturing specification; otherwise, electric shock, injury, or damage to the equipment may result.
- Do not place any object that will hinder ventilation around the reducer; otherwise, the cooling effect is reduced, possibly leading to fire or burns due to excessive heat build – up.
- Do not step on or hang from the reducer; otherwise injury may result.
- Do not touch the shaft end of the reducer, inside keyways, or the edge of the motor cooling fan with bare hands; otherwise, injury may result.
- When the unit is used in food processing applications vulnerable to oil contamination, install an oil pan or other such device to cope with oil leakage due to failure or limited service life; otherwise, oil leakage may damage products.

- Install the unit on a sufficiently rigid base by minimum strength class 10.9 foundation bolts (JIS B 1051).
- Avoid such installation as the housing is deformed.
- Thought the high speed shaft. Center and motor center on a base plate are properly aligned before shipment, align them at the installation. Because the shaft center is not in alignment with the motor center by the transfer or the irregular surface of concrete base.
- Proper amount of oil should be supplied after the installation. (The oil should not be supplied before the installation.)
- High speed shaft, slow speed shaft, key and machine surface for installation are painted with rust – preventive oil. Wash them before the installation. Do not use special solvent and sand – paper for the washing.

## 5. Coupling with other machines

### ⚠ CAUTION

- Confirm the direction of rotation before coupling the unit with the driven machine. Difference in the direction of rotation may cause injury or damage to the equipment.
- When operating the reducer alone (uncoupled), remove the key that is temporarily attached to the output shaft; otherwise, injury may result.
- Cover the rotating parts; otherwise, injury may result.
- When coupling the reducer with a load, check that the centering, the belt tension and parallelism of the pulleys are within the specified limits. When the unit is directly coupled with another machine, check that the direct coupling accuracy is within the specified limits. When a belt is used for coupling the unit with another machine, check the belt tension. Correctly tighten bolts on the pulley and coupling before operation; otherwise, injury may result because of misalignment.

### 5 – 1) Confirmation of direction of rotation

Fig.5 Rotational direction of input shaft and output shaft

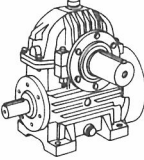
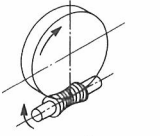
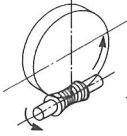
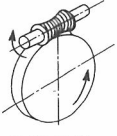
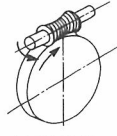
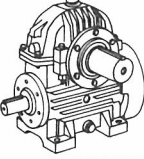
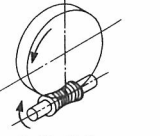
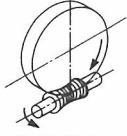
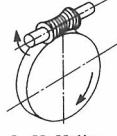
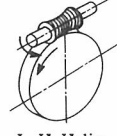
		WORM UNDER		WORM OVER	
Standard (Right hand helix)	CB Type			CT Type	
		 R. H. Helix	 R. H. Helix	 R. H. Helix	 R. H. Helix
Special (Left hand helix)	CB Type			CT Type	
		 L. H. Helix	 L. H. Helix	 L. H. Helix	 L. H. Helix

## 5 – 2) Installation of coupling

- When installing a coupling, do not impact or apply excessive thrust load to the shaft; otherwise, the bearing may be damaged.
- Installation by thermal shrinking is recommended.

### (1) When coupling is used

The accuracy of the dimensions (A, B, and X) shown in Fig.6 should be within the tolerance shown in Table 1.

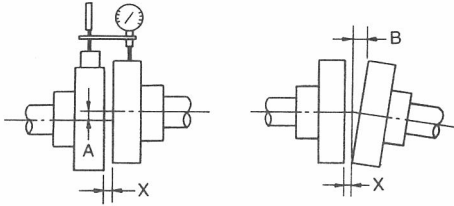

Fig.6

Table 1 Centering accuracy of flexible coupling

Tolerance for A dimension	0.1 mm or maker's specification
Tolerance for B dimension	0.1 mm or maker's specification
X dimension	Maker's specification

### (2) When chain sprocket and gear are used

- The chain tension angle should be perpendicular to the shaft.
- Refer to the chain catalog for the chain tension magnitude.
- Select sprockets and gears whose pitch diameter are three times the shaft diameter or greater.
- Install sprocket and gears so that their point of load application will be closer to the gearmotor or reducer side with respect to the length of the shaft. (Fig.7)

### (3) When V – belt is used

- Excessive V – belt tension will damage the shaft and bearing. Refer to the V – belt catalog for proper tension magnitude.
- The parallelism and eccentricity ( $\beta$ ) between two pulleys should be within  $20'$ . (Fig.8)
- Use a matched set with the same circumferential length when more than one belt is to be installed.

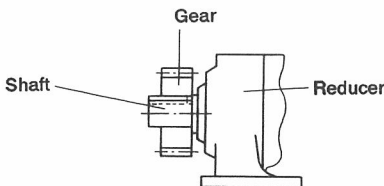

Fig.7

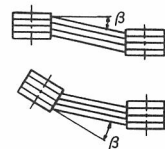

Fig.8

## 6. Operation

### DANGER

- Do not approach or touch rotating parts (output shaft, etc.) during operation; otherwise, loose clothing caught in these rotating parts may result in serious injury or death.

### CAUTION

- Do not put fingers or foreign objects into the opening of the gearmotor or reducer; otherwise electric shock, injury, fire, or damage to the equipment may result.
- The reducer will become very hot during operation. Do not touch or come in contact with the unit; otherwise, burns may result.
- Do not loosen the oil filler plug during operation; otherwise, hot splashing lubricant may cause burns.
- If an anomaly occurs during operation, stop operation immediately; otherwise, electric shock, injury, or fire may result.
- Do not operate the unit in excess of the rating; otherwise, injury or damage to the equipment may result.

- The units are shipped without any oil. Proper amount of oil (Refer to page 14 Table 5) should be supplied before start – up.

After the unit is installed, supplied with oil and properly wired, check the following before starting operation.

- (1) Is the coupling with the driven machine correct?
- (2) Are foundation bolts tightened firmly?
- (3) Is the direction of rotation as required.
- (4) Does the oil level reach above the center of the oil level gauge when the unit is at rest?

After confirming the above items, a break in operation is conducted in accordance with procedures which are showed on page 12.



## Break in operation

In spite of the precision machining, worm gear reducers do not normally exhibit their prescribed performance unless adequately broken in, due to the intrinsic features of gear engagement.

Accordingly, to assure the best conditions under use. We recommend that a break in operation is conducted in accordance with the following procedures. Prior to the commencement of normal operations.

- (1) Gradually increase the load in according with the following sequence.

**Table 2 Break in sequence**

(Unit : Hour)

Break in sequence	Size	63-250 A100~A250	280~400
	(1)No – load start up		0.5
(2)Operation at 25% of full load		2~3	6~9
(3)Operation at 50% of full load		2	6
(4)Operation at 75% of full load		2	6
(5)Operation at full load		2	6

- (2) Particular caution must be given to the oil temperature during the break – in operations. Should the oil temperature rise to above 100°C (Input shaft bearing housing temperatures rises about 90°C) during the break – in operation, the load should be reduced to the preceding load step which is showed on Table2, at which the break – in operation should be repeated.

If the temperature is consistently above 100°C, the cause may be any of the following, which should be thoroughly checked.

- ① The ambient temperature is higher than the specified conditions.
  - ② Over load
  - ③ Inappropriate viscosity of selected lubricant.
- (3) Even though break in operation of the unit has been done, it is recommended that no – load operation is conducted for a while.
  - (4) Any abnormal conditions in the reducer can be grasped during the break – in operations.

If abnormal noise and vibration are noted, the following should be thoroughly checked.

- ① The housing is deformed because the installation surface is irregular.
- ② Resonance is occurring due to the lack of rigidity of the installation base.
- ③ The shaft center is not properly aligned with the mating machine.
- ④ The vibration of the mating machine is transmitted to the reducer.

Nevertheless any abnormal conditions can not be improved, stop operation and contact the nearest agent, dealer or service office.

## 7. Daily inspection and maintenance

### DANGER

- Do not approach or touch any rotating parts (output shaft, etc.) during maintenance or inspection of the unit; otherwise, loose clothing caught in these rotating parts may result in injury or death.
- Do not remove an inspection cover during operation; otherwise, splashing hot lubricant may cause burn.

### CAUTION

- Do not put fingers or foreign objects into the opening of the reducer; otherwise, electric shock, injury, fire, or damage to the equipment may result.
- The reducer will become very hot during operation. Do not touch the unit with bare hands; otherwise, burns may result.
- Identify and provide appropriate corrective action in a timely fashion and according to this maintenance manual if any abnormal operating characteristics are observed. Do not operate the unit until corrective action has been taken.
- Change lubricant according to the maintenance manual. Be sure to use lubricant recommended by us.
- Do not change lubricant during operation or right after operation is stopped; otherwise, burns may result.
- Do not use damaged reducers; otherwise, injury, fire, or damage to the equipment may result.
- We can not assume any responsibility for damage or injury as a result of an unauthorized modification by a customer.
- Dispose of the reducer, lubricant as general industrial waste.

- It is recommended to overhaul the gearmotor or reducer after 20,000 hours or 3 to 5 years of operation to ensure a longer service life, although it depends on the operating conditions.
- Overhauls should be done by appropriately skilld our factory technician. Please contact our nearest agent, distributor or sales office.

## 7 – 1) Daily inspection

To ensure proper and continued optimum operation, use table3 to perform daily inspections.

**Table 3 Daily inspection**

Inspection item	Details of inspection
Noise	Is there abnormal sound? Is there sudden change in sound?
Vibration	Is the vibration abnormally large? Does vibration change suddenly?
Surface temperature	Is the surface temperature abnormally high? Does the surface temperature rise suddenly?
Oil level	Does the oil level reach the upper of the oil gauge center when the unit is at rest?
Foundation bolt	Are foundation bolts loose?
Chain and V – belt	Are chain and V – belt loose?
Oil	Does oil glitter by metal chips in the oil?
Oil leakage	Does oil leak from gear section?

When some anomaly is found during the daily inspection, take corrective measures according to section 9. Troubleshooting (page 17) If the anomaly cannot be eliminated, contact our nearest agent, distributor, or sales office.

## 7 – 2) Lubrication method

Lubrication method for gear portion of standard model is oil bath. Lubrication methods for bearings of standard model are oil bath and splase oil.

## 7 – 3) Supply and change of lubrication oil

### (1) Lubrication oil change interval

**Table 4 Lubrication oil change interval**

Oil supply	Change interval	
	Right after purchase	
Oil change	1st change	After 500hrs of operation.
	Subsequent changes	After every 5000hrs of operation or once every year

### (2) Lubrication

Use a polyglycol synthetic oil for lubrication to ensure the full high performance of the Hedcon worm gear reducers.

**Table 5 Recommended lubricants**

Oil Brand	Input speed (rpm)	
	Lower than 500	500-1800
Shell Oil	Tivela Oil SD (460EP)	Tivela Oil SB (220EP)
NOK Kluber	Syntheso HT460	Syntheso HT220
Japan Energy Co.	JOMO Reductus SHT460	JOMO Reductus SHT220

### (3) Q'ty of oil

- Specification sheet show approx. quantity of oil.
- Before operation, check the oil level with oil gauge.
- In order to constantly check the oil level, a window type oil gauge has been mounted at easily visible position on the housing. Supply oil upto a level slightly above the center of the oil level gauge, while the reducer is stopped. Upon completion of the oil filling, conduct a no – load operation until the lubrication has thoroughly spread throughout the gears and bearings, after which the reducer should be stopped and the oil level should be checked for adequacy.
- If the oil level is near is near the center of the oil level gauge, this should be adequate. During operations, the oil level may vary considerably, which must be carefully observed, as the oil quantity may be insufficient, even though the oil gauge may show a level within the prescribed level.

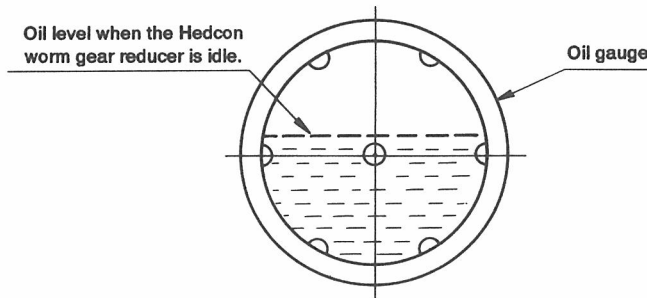

Fig.9 Oil level gauge

### (4) Change of lubricant

#### (i) Periodical change

- ① Discharge the used oil
- ② After discharging, fill with new oil.

In the case of oil polution, flushing should be conducted in accordance with the following (ii) procedures.

#### (ii) Change of lubricant at oil polution.

- ① Discharge the used oil
- ② Fill with low viscosity flushing oil
- ③ No – load operation for several minutes
- ④ Discharge the flushing oil
- ⑤ Fill with minimum quantity of designated oil
- ⑥ No – load operation for several minutes
- ⑦ After discharging the fore going oil, fill with new oil

#### 7 – 4) Inspection and replacement of oil seals.

Wear in the seals may cause oil leakage, for which reason they should be regularly inspected and replaced adequately in advance.

Different seals from existence should be avoided, since they soon lead to oil leakage.

Consult our service office to replace the oil seal.

---

### **8. Disassembly and assembly**

- Do not disassemble the unit.
- To assure that this reducer can exhibit its full functional potential, the gear engagements and bearing clearances have been adjusted with high precision.
- Consult us whenever disassembly becomes unavoidable.

## 9. Troubleshooting

- If an anomaly occurs in the reducer, refer to Table 6 below and take appropriate measures as soon as possible.

**Table 6 Troubleshooting**

Problem	Possible cause	Correction
Excessive temperature rise	Overload	Decrease the load
	Oil pollution or unsuitable oil are used	Discharge the used oil, conduct flushing and then fill with new oil
	Oil quantity is unsuitable. Insufficient or too much	Oil quantity should be suitable
	Bearing clearance is too narrow.	Return the unit to factory for servicing
Oil leakage	Damaged oil seal	Replace the oil seal with a new one
	Damaged oil gauge	Replace the oil gauge with a new one
	Damaged packing	Replace the packing with a new one
	Loose bolts & plugs	Tighten bolts correctly
Abnormal sound Abnormal vibration	Damaged bearing	Return the unit to factory for servicing
	Gear engagement is unsuitable	
	Bearing clearance is too narrow	
	Damaged gear	
	Oil quantity is insufficient	Add oil
	Entry of foreign matter into oil	Replace the oil
Output shaft does not rotate	There is no tooth due to wear	Return the unit to factory for servicing
	Breakage of high speed shaft or slow speed shaft	
	Breakage of key between worm wheel and wheel shaft	
	In the case of gearmotor, breakage of key between motor shaft and high speed shaft or motor shaft itself	
Input and output do not rotate	Entry of foreign matter into gear engagement	Return the unit to factory for servicing
	Bearing is burned or damaged	
	Teeth surface is burned	

## 10. Construction drawing

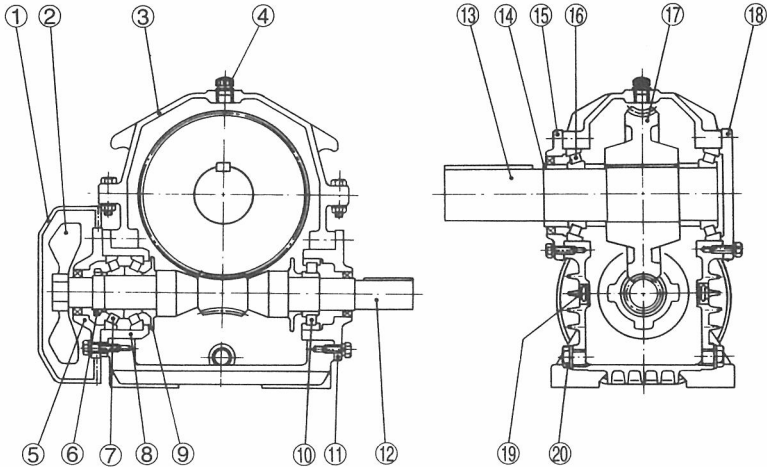

Note: ● This is a model construction based on the CB type.

● This only shows an example of the basic structures and may differ according to type or size.

Table 7 Main parts

No.	Parts name	No.	Parts name	No.	Parts name
1	fan cover	8	bearing cage (1)	15	output shaft cover (1)
2	fan	9	oil fringer plate	16	taper roller bearing
3	housing	10	cylindrical roller bearing	17	worm wheel
4	oil filler	11	bearing cage (2)	18	output shaft cover (2)
5	worm shaft cover	12	worm shaft	19	oil gauge
6	nut for bearing	13	output shaft	20	oil drain plug
7	taper roller bearing	14	collar		

## 11. Bearing list

Table 8 Bearing list

Size	High speed shaft bearing				Solid shaft bearing		Hollow shaft bearing	Q'ty
	Input side		Fan side	Q'ty	Standard	Q'ty		
	Standard	Q'ty						
63	4T – 30305D	1	4T – 30305D	1	4T – 30208	2	32014XU	2
80	4T – 30307D	1	4T – 30307D	1	4T – 30210	2	32017XU	2
100, A100	4T – 30308D	1	4T – 30308D	1	30212U	2	32020XU	2
125, A125	4T – 30309D	1	4T – 30309D	1	30214U	2	32021XU	2
150, A150	NJ310	1	4T – 30310D	2	30216U	2	32022XU	2
175, A175	NJ312	1	4T – 30312D	2	30218U	2	32024XU	2
200, A200	NJ313	1	4T – 30313D	2	30220U	2	32028XU	2
225, A225	NJ315	1	30316DU	2	30222U	2	32034XU	2
250, A250	NJ316	1	30318DU	2	30224U	2	32038XU	2
280	NJ322M	1	30322D	2	30228	2	32944	2
320	NJ324M	1	30324D	2	30232	2	32952	2
360	NJ326M	1	30326D	2	30236	2	32956	2
400	NJ328M	1	30330D	2	30240	2	32960	2

NTN – made Bearings are recommended for size 63~250.

NSK – made Bearings are recommended for size 280~400.

## 12. Oil seal list

Table 9 Oil seal list

Size	High speed shaft			Output shaft					
				Solid shaft			Hollow shaft		
63	D25	40	8A	D40	58	8A	D65	88	12A
80	D35	55	11A	D50	70	10A	D80	105	13A
100, A100	D40	58	8A	D60	82	12A	D95	120	13A
125, A125	D45	62	9A	D70	95	13A	D100	125	13A
150, A150	D45	62	9A	D95	120	13A	D105	135	14A
	D50	70	10A						
175, A175	D55	78	12A	D110	145	15A	D115	140	15A
200, A200	D60	82	12A	D120	155	16A	D140	170	14A
225, A225	D70	95	13A	D130	160	14A	D160	190	16A
250, A250	D75	100	13A	D140	170	14A	D180	210	16A
280	S95	120	13A	D160	190	15A	D220	250	16A
320	S110	140	14A	D180	210	16A	D250	280	15A
360	S110	140	14A	D220	250	16A	D280	320	22A
400	S120	150	14A	D230	270	16A	D300	340	22A

Meaning of alphabet D: Spring loaded, rubber covered with dust – lip S: Spring loaded, rubber covered A: This oil seal is made of nitride rubber.

Koyo – made oil seal should be used for high speed shaft side oil seal.

Table 9 show standard oil seals.

Whether oil seals of customer's unit is standard or special should be check by specific sheet.



## 13. Warranty

The scope of our warranty for our products is limited to the range of our manufacture.

Warranty (period and contents)

Warranty period	The warranty period of the product shall be eighteen (18) months after shipment from the factory or twelve (12) months after operation, whichever comes first, provided that the product under this warranty is new.
Items of warranty	<ol style="list-style-type: none"> <li>1. It is warranted that the product operates normally under the conditions for which it is installed, coupled, and maintained in conformity with the descriptions in the maintenance manual and is operated correctly according to the specifications shown in the catalog or those agreed upon separately.</li> <li>2. It is warranted that parts of the product are made of proper materials and machined in accordance with established criteria, and that the product is coated, packed, and transported in accordance with established criteria.</li> <li>3. It is warranted that the shipped product conforms to the outline drawing and specifications.</li> <li>4. The scope of warranty is limited to the scope of our manufacture.</li> <li>5. The following is beyond the scope of the warranty.             <ol style="list-style-type: none"> <li>① When the product is not properly mounted or connected to other units, resulting in nonconformance.</li> <li>② When the product is not properly maintained, controlled, and handled.</li> <li>③ When the product is operated without conforming to the design specifications.</li> <li>④ When the user of the product has altered or modified the product in any way.</li> <li>⑤ When the product is subjected to secondary failure due to the nonconformance of the unit which is connected by the user to the product.</li> <li>⑥ When the product has been damaged due to the use of defective parts supplied or designated by the user.</li> <li>⑦ When the cause of trouble of the product arises from an earthquake, fire, flood, lighting, and other force majeure.</li> <li>⑧ When the product has been damaged due to reasons other than the above, for which Sumitomo is not responsible.</li> </ol> </li> </ol>